

2023 FULL SUSPENSION FRAMES GEOMETRY

	model	*calc. fork travel	reach (mm)	stack (mm)	ST (mm)	TT (mm)	eTT (mm)	CS (mm)	HT (mm)	HT angle (°)	eST angle (°)	BB drop	WB (mm)	stand-over (mm)	wheel size (")	max. tire size (")	max. chainring size	frame travel (mm)	shock size (mm)	shock hardware (mm)	**fork travel (mm)	hub size	headset type (S.H.I.S)	BB type (mm)	post diam. (mm)	clamp diam. (mm)	brake mount	max. rotor size (mm)
THUNDERBIRD CF																												
	MEDIUM	170	455	633	437	-	613	435	110	64	76	27	1237	760	29	29x2.6	36T	160	205x65	Trunnion/22.2x8	160-170	148x12	IS42/IS52	BSA/Euro 73	30.9	34.9	PM 180mm	203
	LARGE	170	480	633	452	-	638	435	110	64	76	27	1262	760	29	29x2.6	36T	160	205x65	Trunnion/22.2x8	160-170	148x12	IS42/IS52	BSA/Euro 73	30.9	34.9	PM 180mm	203
THUNDERBIRD SUPERENDURO																												
	SMALL	180	435	640	430	-	590	435	110	64	76	25	1219	806	29	29x2.6	36T	170	205x65	Trunnion/22.2x8	170-190	148x12	IS42/IS60	BSA/Euro73	30.9	34.9	PM 180mm	203
	MEDIUM	180	460	640	450	-	615	435	110	64	76	25	1244	806	29	29x2.6	36T	170	205x65	Trunnion/22.2x8	170-190	148x12	IS42/IS60	BSA/Euro73	30.9	34.9	PM 180mm	203
	LARGE	180	485	640	470	-	640	435	110	64	76	25	1269	806	29	29x2.6	36T	170	205x65	Trunnion/22.2x8	170-190	148x12	IS42/IS60	BSA/Euro73	30.9	34.9	PM 180mm	203
THUNDERBIRD FR																												
	MEDIUM	180	445	619	430	-	540	430	110	65	81	12	1206	795	27.5/Mullet	27.5x2.6	36T	180	225x75	Trunnion/22.2x8	180-200	148x12	IS42/IS60	BSA/Euro73	30.9	34.9	PM 180mm	203
	LARGE	180	470	619	450	-	565	430	110	65	81	12	1231	795	27.5/Mullet	27.5x2.6	36T	180	225x75	Trunnion/22.2x8	180-200	148x12	IS42/IS60	BSA/Euro73	30.9	34.9	PM 180mm	203
BLACKBIRD 29																												
	MEDIUM	160	450	635	450	-	594	448	120	65	77	30	1235	825	29	29x2.5	34T	160	230x65	22.2x8	160-170	148x12	IS42/IS52	BSA/Euro73	30.9	34.9	PM 160mm	203
	LARGE	160	480	635	480	-	624	448	120	65	77	30	1265	825	29	29x2.5	34T	160	230x65	22.2x8	160-170	148x12	IS42/IS52	BSA/Euro73	30.9	34.9	PM 160mm	203
	XLARGE	160	505	635	490	-	649	448	120	65	77	30	1290	825	29	29x2.5	34T	160	230x65	22.2x8	160-170	148x12	IS42/IS52	BSA/Euro73	30.9	34.9	PM 160mm	203
BLACKBIRD 27.5																												
	SMALL	160	400	606	405	-	552	429	120	65	76	14	1151	790	27.5	27.5x2.5	34T	160	230x65	22.2x8	160-170	148x12	IS42/IS52	BSA/Euro73	30.9	34.9	PM 160mm	203
	MEDIUM	160	435	606	430	-	587	429	120	65	76	14	1186	790	27.5	27.5x2.5	34T	160	230x65	22.2x8	160-170	148x12	IS42/IS52	BSA/Euro73	30.9	34.9	PM 160mm	203
	LARGE	160	460	606	455	-	612	429	120	65	76	14	1211	790	27.5	27.5x2.5	34T	160	230x65	22.2x8	160-170	148x12	IS42/IS52	BSA/Euro73	30.9	34.9	PM 160mm	203
	XLARGE	160	485	606	480	-	637	429	120	65	76	14	1236	790	27.5	27.5x2.5	34T	160	230x65	22.2x8	160-170	148x12	IS42/IS52	BSA/Euro73	30.9	34.9	PM 160mm	203
BLACKBIRD JR																												
	ONE SIZE	130	365	558	360	-	502	425	100	66	73	14	1075	750	26	26x2.5	34T	130	165x38	22.2 x 8	130-140	148x12	IS42/IS52	BSA/Euro73	30.9	34.9	PM 160mm	180
BLUEBIRD 29																												
	MEDIUM	130	435	618	450	-	587	439	110	66	76	35	1178	820	29	29x2.4	34T	130	210x50	22.2x8	130-150	148x12	IS42/IS52	BSA/Euro73	30.9	34.9	IS	180
	LARGE	130	460	618	460	-	612	439	110	66	76	35	1203	820	29	29x2.4	34T	130	210x50	22.2x8	130-150	148x12	IS42/IS52	BSA/Euro73	30.9	34.9	IS	180
	XLARGE	130	485	618	480	-	637	439	110	66	76	35	1228	820	29	29x2.4	34T	130	210x50	22.2x8	130-150	148x12	IS42/IS52	BSA/Euro73	30.9	34.9	IS	180
BLUEBIRD 27.5																												
	SMALL	130	415	597	400	-	590	431	110	66	74	23	1136	785	27.5/Mullet	27.5x2.8"	34T	130	210x50	22.2x8	130-150	148x12	IS42/IS52	BSA/Euro73	30.9	34.9	IS	180
	MEDIUM	130	435	597	430	-	610	431	110	66	74	23	1156	785	27.5/Mullet	27.5x2.8"	34T	130	210x50	22.2x8	130-150	148x12	IS42/IS52	BSA/Euro73	30.9	34.9	IS	180
	LARGE	130	465	597	460	-	640	431	110	66	74	23	1186	785	27.5/Mullet	27.5x2.8"	34T	130	210x50	22.2x8	130-150	148x12	IS42/IS52	BSA/Euro73	30.9	34.9	IS	180
SHINE																												
	ONE SIZE	100	424	573	345	547	-	390	120	69	73	15	1074	-	26	26x2.4	32T	100	190x51	22.2 x 8	100-140	135x10	IS42/IS52	BSA/Euro73	30.9	34.9	IS	160

* fork travel used for calculating the geometry showed in this table (in millimeters) ** recommended fork travel range (in millimeters)

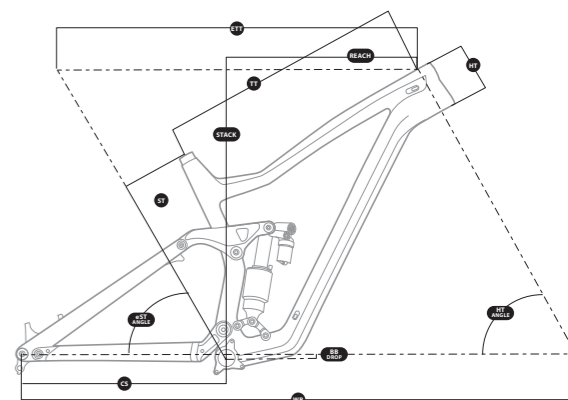

- reach** – horizontal distance from BB center to HT center
- stack** – vertical distance from BB center to HT top
- ST** – seat tube length (BB center to ST top)
- TT** – top tube length (actual)
- eTT** – top tube length (effective)
- CS** – chain stay length
- HT** – head tube length
- HT angle** – head tube angle
- eST angle** – effective seat tube angle
- BB drop** – bottom bracket height (BB center to WB)
- WB** – wheel base
- standover** – vertical distance from the ground to TT top (in the middle of the TT length with wheels assembled)

#RIDEYOURWAY