

	model	*calc. fork travel	reach (mm)	stack (mm)	ST (mm)	TT (mm)	eTT (mm)	CS (mm)	HT (mm)	HT angle (°)	ST angle (°)	BB drop	WB (mm)	stand-over (mm)	wheel size (")	max. tire size (")	max. chainring size	frame travel (mm)	shock size (mm)	shock hardware (mm)	**fork travel (mm)	hub size	headset type (S,H,I,S)	BB type (mm)	post diam. (mm)	clamp diam. (mm)	brake mount	max. rotor size (mm)	front derailleur compat.	weight (kg)	
THUNDERBIRD CF																															
	MEDIUM	170	455	600	450	588	610	435	110	64	76	28	1232	760	29	29x2.6	36T	160	205x65	Trunnion/20x8	160-170	148x12	IS42/IS52	BSA/Euro73	30.9	34.9	PM 180mm	203	no	2.7 (without shock);	
	LARGE	170	480	600	465	588	639	435	110	64	76	28	1257	760	29	29x2.6	36T	160	205x65	Trunnion/20x8	160-170	148x12	IS42/IS52	BSA/Euro73	30.9	34.9	PM 180mm	203	no	3.15 (with Fox X2 Factory shock)	
BLACKBIRD 29																															
	MEDIUM	160	450	635	450	590	594	448	120	65	77	30	1235	825	29	29x2.5	34T	160	230x65	22.2x8	160-170	148x12	IS42/IS52	BSA/Euro73	30.9	34.9	PM 160mm	203	no	3.6 (without shock);	
	LARGE	160	480	635	480	616	624	448	120	65	77	30	1265	825	29	29x2.5	34T	160	230x65	22.2x8	160-170	148x12	IS42/IS52	BSA/Euro73	30.9	34.9	PM 160mm	203	no	3.95 (with RS Super Deluxe Select metric shock)	
	XLARGE	160	505	635	490	638	649	448	120	65	77	30	1290	825	29	29x2.5	34T	160	230x65	22.2x8	160-170	148x12	IS42/IS52	BSA/Euro73	30.9	34.9	PM 160mm	203	no		
BLACKBIRD 27.5																															
	SMALL	160	400	606	405	545	552	429	120	65	76	14	1151	790	27.5	27.5x2.5	34T	160	230x65	22.2x8	160-170	148x12	IS42/IS52	BSA/Euro73	30.9	34.9	PM 160mm	203	no	3.45 (without shock);	
	MEDIUM	160	435	606	430	577	587	429	120	65	76	14	1186	790	27.5	27.5x2.5	34T	160	230x65	22.2x8	160-170	148x12	IS42/IS52	BSA/Euro73	30.9	34.9	PM 160mm	203	no		
	LARGE	160	460	606	455	598	612	429	120	65	76	14	1211	790	27.5	27.5x2.5	34T	160	230x65	22.2x8	160-170	148x12	IS42/IS52	BSA/Euro73	30.9	34.9	PM 160mm	203	no	3.8 (with RS Super Deluxe Select metric shock)	
	XLARGE	160	485	606	480	620	637	429	120	65	76	14	1236	790	27.5	27.5x2.5	34T	160	230x65	22.2x8	160-170	148x12	IS42/IS52	BSA/Euro73	30.9	34.9	PM 160mm	203	no		
BLUEBIRD 29																															
	MEDIUM	130	435	618	450	558	587	439	110	66	76	35	1178	820	29	29x2.4	34T	130	210x50	22.2x8	130-150	148x12	IS42/IS52	BSA/Euro73	30.9	34.9	PM 160mm	180	no	3.15 (without shock);	
	LARGE	130	460	618	460	582	612	439	110	66	76	35	1203	820	29	29x2.4	34T	130	210x50	22.2x8	130-150	148x12	IS42/IS52	BSA/Euro73	30.9	34.9	PM 160mm	180	no	3.35 (w/Fox Float DPS metric shock 210x50mm)	
	XLARGE	130	485	618	480	606	637	439	110	66	76	35	1228	820	29	29x2.4	34T	130	210x50	22.2x8	130-150	148x12	IS42/IS52	BSA/Euro73	30.9	34.9	PM 160mm	180	no		
BLUEBIRD 27.5																															
	SMALL	130	415	597	400	544	590	431	110	66	74	23	1136	785	27.5	27.5x2.8	34T	130	210x50	22.2x8	130-150	148x12	IS42/IS52	BSA/Euro73	30.9	34.9	PM 160mm	180	no	3.1 (without shock);	
	MEDIUM	130	435	597	430	563	610	431	110	66	74	23	1156	785	27.5	27.5x2.8	34T	130	210x50	22.2x8	130-150	148x12	IS42/IS52	BSA/Euro73	30.9	34.9	PM 160mm	180	no	3.3 (w/Fox Float DPS metric shock 210x50mm)	
	LARGE	130	465	597	460	594	640	431	110	66	74	23	1186	785	27.5	27.5x2.8	34T	130	210x50	22.2x8	130-150	148x12	IS42/IS52	BSA/Euro73	30.9	34.9	PM 160mm	180	no		
BLACKBIRD JR																															
		130	365	558	360	492	502	425	100	66	73	14	1075	750	26	26x2.5	34T	130	165x38	22.2 x 8	130-140	142x12	IS42/IS52	BSA/Euro73	30.9	34.9	PM 160mm	180	no	3.05 (without shock)	
HORNET																															
	SMALL	160	405	625	380	594	596	425	120	64	73	35	1158	805	27.5/27.5+	27.5x2.8	36T	-	-	-	140-180	148x12	IS42/IS52	BSA/Euro73	30.9	34.9	PM 160mm	203	no	2.6	
	MEDIUM	160	430	625	410	615	620	425	120	64	73	35	1183	805	27.5/27.5+	27.5x2.8	36T	-	-	-	140-180	148x12	IS42/IS52	BSA/Euro73	30.9	34.9	PM 160mm	203	no	2.65	
	LARGE	160	460	625	440	643	650	425	120	64	73	35	1213	805	27.5/27.5+	27.5x2.8	36T	-	-	-	140-180	148x12	IS42/IS52	BSA/Euro73	30.9	34.9	PM 160mm	203	no	2.7	
	XLARGE	160	480	625	455	657	672	425	120	64	73	35	1233	805	27.5/27.5+	27.5x2.8	36T	-	-	-	140-180	148x12	IS42/IS52	BSA/Euro73	30.9	34.9	PM 160mm	203	no	2.7	
HORNET JR																															
		100	360	527	305	514	521	390	90	68	73	30	993	700	24	24x2.5	34T	-	-	-	100-140	135x10	IS42/IS52	BSA/Euro73	30.9	34.9	IS	160	no	1.85	
PRIMAL 29																															
	SMALL	140	410	636	435	-	600	432	100	66	73.5	62	1149	790	29	29x2.4	34T	-	-	-	130-160	148x12	IS42/IS52	BSA/Euro73	30.9	34.9	IS	180	no		
	MEDIUM	140	430	636	455	-	620	432	100	66	73.5	62	1169	790	29	29x2.4	34T	-	-	-	130-160	148x12	IS42/IS52	BSA/Euro73	30.9	34.9	IS	180	no	2.25	
	LARGE	140	450	636	475	-	640	432	100	66	73.5	62	1189	790	29	29x2.4	34T	-	-	-	130-160	148x12	IS42/IS52	BSA/Euro73	30.9	34.9	IS	180	no		
	XLARGE	140	470	636	495	-	660	432	100	66	73.5	62	1209	790	29	29x2.4	34T	-	-	-	130-160	148x12	IS42/IS52	BSA/Euro73	30.9	34.9	IS	180	no		
PRIMAL 27.5																															
	SMALL	140	410	617	435	-	593	420	115	65.5	73.5	47	1145	790	27.5	27.5x2.6	34T	-	-	-	130-160	148x12	IS42/IS52	BSA/Euro73	30.9	34.9	IS	180	no		
	MEDIUM	140	430	617	455	-	613	420	115	65.5	73.5	47	1165	790	27.5	27.5x2.6	34T	-	-	-	130-160	148x12	IS42/IS52	BSA/Euro73	30.9	34.9	IS	180	no	2.28	
	LARGE	140	450	617	475	-	633	420	115	65.5	73.5	47	1185	790	27.5	27.5x2.6	34T	-	-	-	130-160	148x12	IS42/IS52	BSA/Euro73	30.9	34.9	IS	180	no		
	XLARGE	140	470	617	495	-	653	420	115	65.5	73.5	47	1205	790	27.5	27.5x2.6	34T	-	-	-	130-160	148x12	IS42/IS52	BSA/Euro73	30.9	34.9	IS	180	no		
HORNET 26																															
		140	420	565	330	573	603	400	100	68	70	30	1078	-	26	26x2.4	34T	-	-	-	100-160	148x12	IS42/IS52	BSA/Euro73	30.9	34.9	IS	180	no	2.25	
STREETFIGHTER																															
		100	425	560	335	572	570	400	100	70	75	25	1066	-	26	26x2.5	32T	-	-	-	100-150	135x10	IS42/IS52	BSA/Euro73	30.9	34.9	IS	180	no	2.3	
SHINE																															
		100	424	573	345	547	-	390	120	69	73	15	1074	-	26	26x2.4	32T	100	190x51	22.2 x 8	100-140	135x10	IS42/IS52	BSA/Euro73	30.9	34.9	IS	160	no	3.2	
TWO6PLAYER																															
	SHORT	100	400	573	337	556	-	385	120	69	74	25	1043	-	26	26x2.35	32T	-	-	-	90-130	135x10	IS42/IS52	BSA/Euro73	30.9	34.9	IS	160	no	2.2	
	LONG	100	425	573	337	577	-	385	120	69	74	25	1068	-	26	26x2.35	32T	-	-	-	90-130	135x10	IS42/IS52	BSA/Euro73	30.9	34.9	IS	160	no	2.25	
TWO6PLAYER PUMP																															
		100	410	573	337	565	-	385	120	69	74	25	1053	-	26	26x2.35	32T	-	-	-	90-130	135x10	IS42/IS52	BSA/Euro73	30.9	34.9	IS	160	no	2.1	
CODY TAPERED																															
		100	400	558	300	570	-	380	110	69	-	15	1040	-	26	26x2.35	-	-	-	-	80-110	135x10	IS42/EC44	Spanish 68	27.2	integr.	IS	160	no	2.26	
QUINNIE TAPERED																															
		100	412	558	300	576	-	383	110	69	-	15	1054	-	26	26x2.35	-	-	-	-	80-110	135x10	IS42/IS52	Euro 68	27.2	integr.	IS	160	no	2.45	

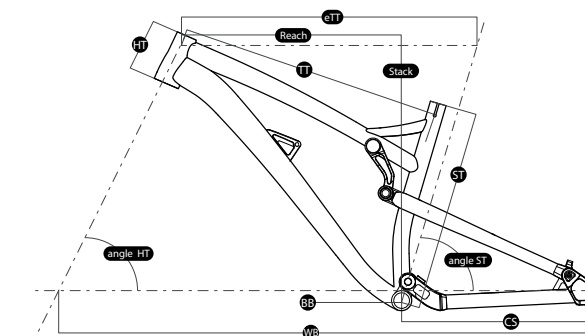

- reach** – horizontal distance from BB center to HT center
- stack** – vertical distance from BB center to HT top
- ST** – seat tube length (BB center to ST top)
- TT** – top tube length (actual)
- eTT** – top tube length (effective)
- CS** – chain stay length
- HT** – head tube length
- HT angle** – head tube angle
- ST angle** – seat tube angle
- BB drop** – bottom bracket height (BB center to WB)
- WB** – wheel base
- standover** – vertical distance from the ground to TT top (in the middle of the TT length with wheels assembled)